

# Commercial Stainless

ITEM # \_\_\_\_\_

QTY. \_\_\_\_\_

MODEL # C3CSD

## THREE (3) COMPARTMENT SINK WITH DRAINBOARDS

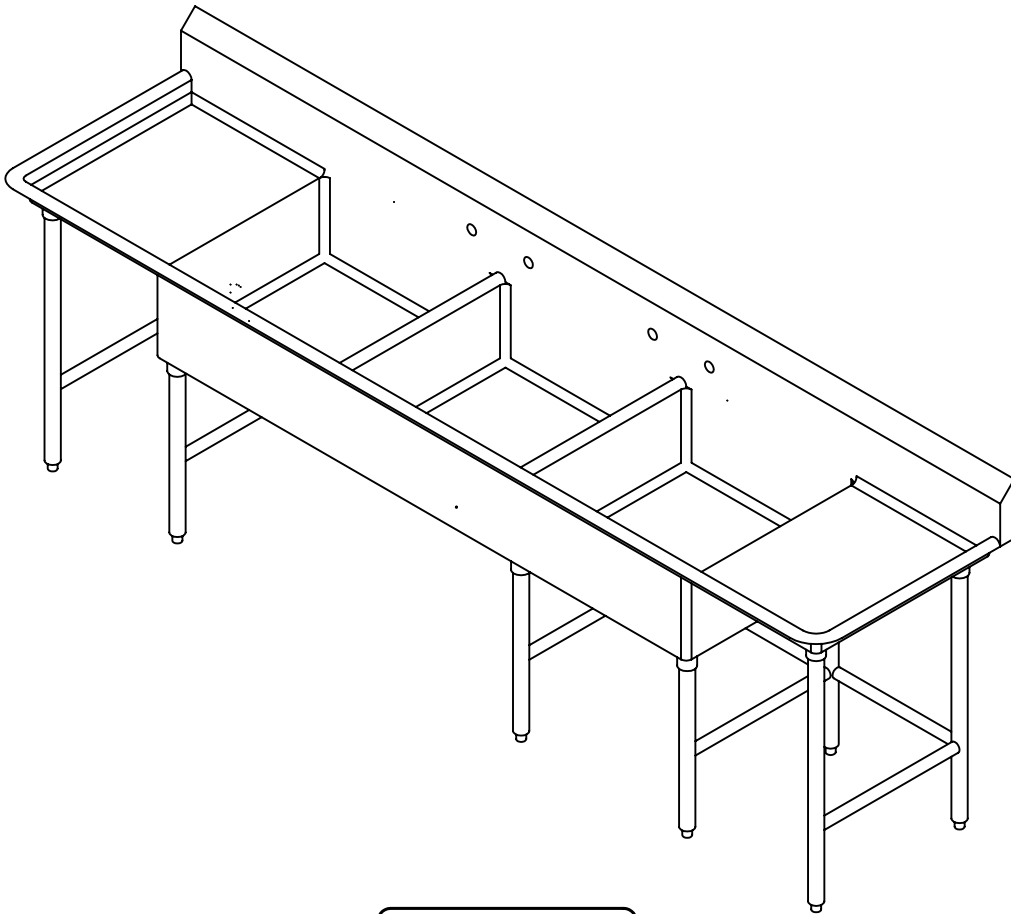

### SPECIFICATIONS

THREE (3) COMPARTMENT SINK & DRAINBOARDS TO BE 14 GA. TYPE 304, 18/8 STAINLESS STEEL, POLISHED TO A # 4 SATIN FINISH. ALL SEAMS TO BE CONTINUOUSLY WELDED, GROUND SMOOTH, & POLISHED. ALL HORIZONTAL & VERTICAL CORNERS ARE TO BE 3/4" R. COVED CORNERS. 8" HIGH SPLASH TO BE 2" THICK WITH RETURN TO WALL ON A 45° ANGLE. LEGS TO BE 1 5/8" O.D. S/S TUBING WITH ADJUSTABLE S/S BULLET FEET. S/S LEG GUSSETS TO BE WELDED TO S/S CHANNEL. S/S CHANNEL IS TO BE STUD BOLTED TO TOP. SINKS TO BE SUPPLIED WITH 1 1/2" BASKET DRAIN. CROSSBRACING TO BE 1" O.D. S/S TUBING CONTINUOUSLY WELDED TO LEGS. SINKS TO BE SEPARATED BY A 1 1/2" THICK PARTITION WITH THE TOP EDGE ROLLED ON A 3/4" RADIUS. DRAINBOARDS EXCEEDING 24" IN LENGTH TO HAVE S/S CHANNEL & LEGS.

955 PATTERSON DRIVE  
BLOOMSBURG, PA. 17815  
TELEPHONE: (570) 387-8980 FAX: (570) 387-8982



CUSTOM BUILT  
FOODSERVICE  
EQUIPMENT

NSF

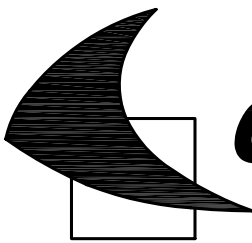

# Commercial Stainless

ITEM # \_\_\_\_\_

QTY. \_\_\_\_\_

MODEL # C3CSD

## THREE (3) COMPARTMENT SINK WITH DRAINBOARDS

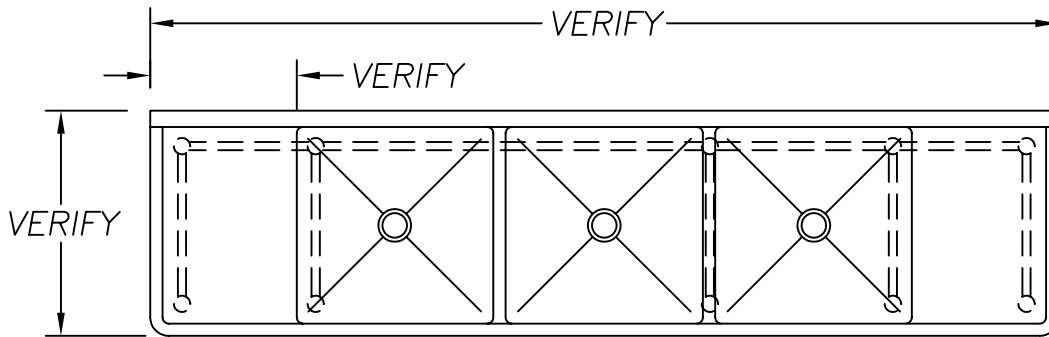

PLAN VIEW

NOTE: FAUCET TO BE SUPPLIED BY OTHERS

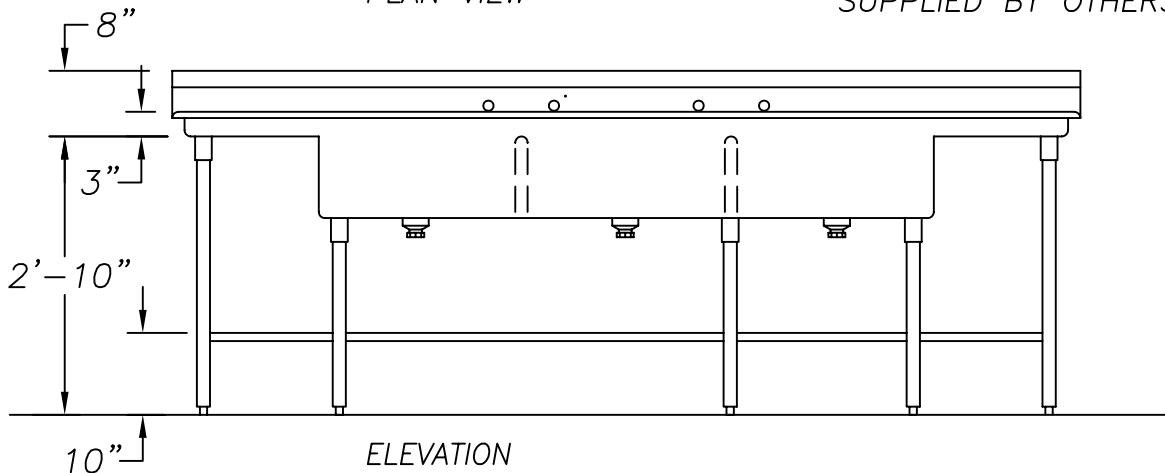

ELEVATION

SINKS TO BE \_\_\_\_\_" LEFT TO RIGHT X \_\_\_\_\_" FRONT TO BACK X \_\_\_\_\_" DEEP

### OPTIONS

- |                                 |                              |
|---------------------------------|------------------------------|
| 1. ROLLED MARINE EDGE           | 2. LEFT END SPLASH           |
| 3. SPECIAL SPLASH HEIGHT        | 4. RIGHT END SPLASH          |
| 5. 1 1/4" O.D. S/S CROSSBRACING | 6. DISPOSER CONE             |
| 7. OPTIONAL DRAIN               | 8. DISPOSER COLLAR           |
| 9. SOUND DEADENING              | 10. DISPOSER CONTROL BRACKET |
| 11. S/S WALL SPACERS            | 12. OPTIONAL UNDERSHELF      |

955 PATTERSON DRIVE  
BLOOMSBURG, PA. 17815  
TELEPHONE: (570) 387-8980 FAX: (570) 387-8982



CUSTOM BUILT  
FOODSERVICE  
EQUIPMENT 