

Commercial Stainless

ITEM # _____

QTY. _____

MODEL # CDO

DOUBLE OVERSHELF

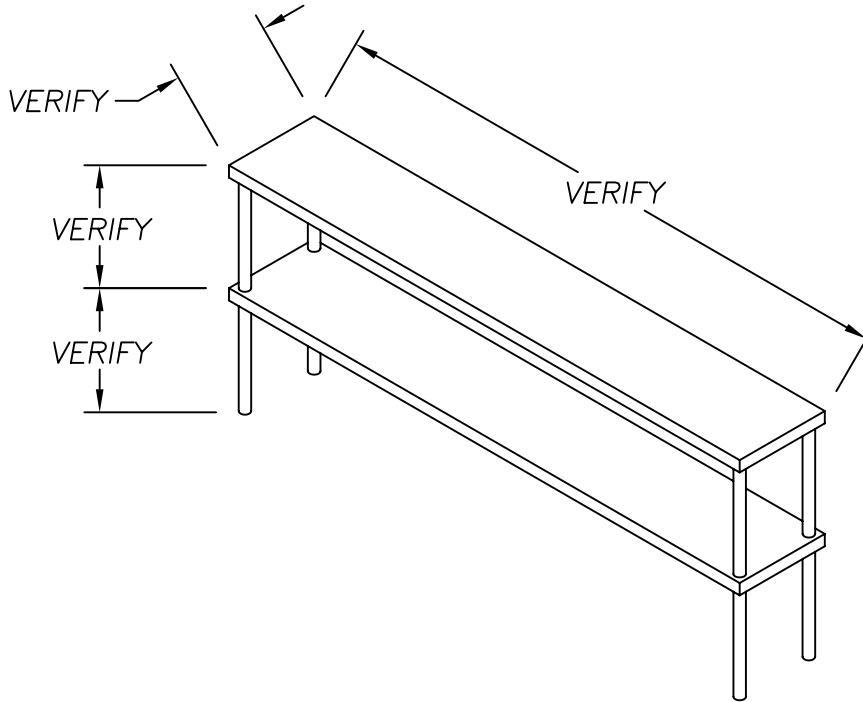

SPECIFICATIONS

DOUBLE OVERSHELF TO BE 18 GA. TYPE 304, 18/8 STAINLESS STEEL, POLISHED TO A # 4 FINISH. ALL SEAMS TO BE CONTINUOUSLY WELDED, GROUND, & POLISHED. UPRIGHTS TO BE 1 1/4" O.D. S/S TUBING WITH EXPANDERS FOR FASTENING TO TOP.

OPTIONS

- | | |
|-------------------------|------------------------------------------------------------------------------|
| 1. 16 GA. S/S SHELVES | 2. S/S ESCUTCHEONS |
| 3. 1" O.D. S/S UPRIGHTS | 4. SURFACE MOUNTED RECEPTACLE |
| 5. ROLLED EDGES | 6. HEAT LAMP BRACKETS
(HEAT LAMP MAKE _____)
(HEAT LAMP MODEL # _____) |

955 PATTERSON DRIVE
BLOOMSBURG, PA. 17815
TELEPHONE: (570) 387-8980 FAX: (570) 387-8982



CUSTOM BUILT
FOODSERVICE
EQUIPMENT 