

PLAN VIEW 1/2"=1'-0"

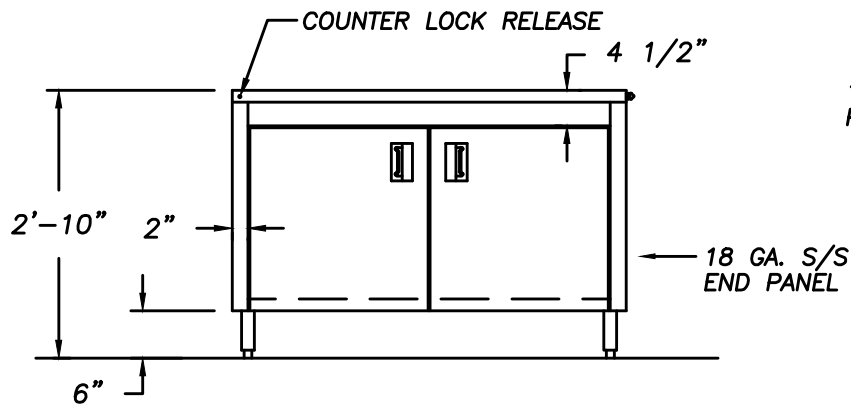

REAR ELEVATION 1/2"=1'-0"

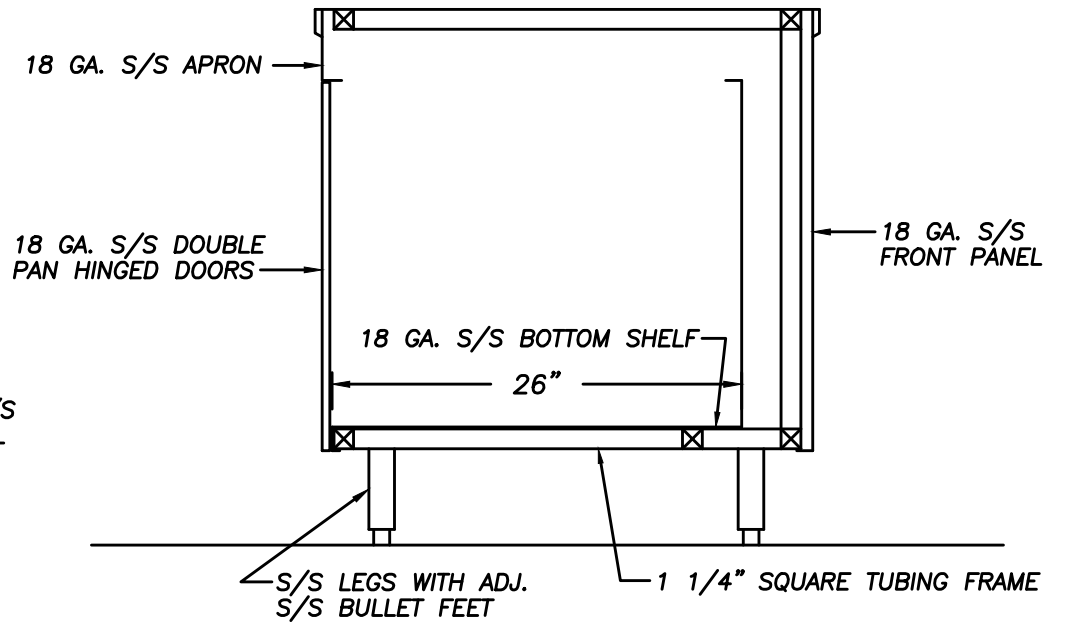

SECTION 1"=1'-0"

NOTES:

- 14 GA. S/S TOP
- 18 GA. S/S EXTERIOR PANELS
- 18 GA. S/S BOTTOM SHELF AND ENDS
- S/S LEGS WITH ADJ. S/S BULLET FEET
- 1 1/4" SQUARE TUBING FRAME
- 18 GA. S/S DOUBLE PAN HINGED DOORS
- LAMINATED PANELS OPTIONAL
- 5" DIA. SWIVEL CASTERS WITH BRAKES OPTIONAL

AHD HINGED DOORS



955 PATTERSON DRIVE
 BLOOMSBURG, PA. 17815
 TELEPHONE: (570) 387-8980 FAX: (570) 387-8982



CUSTOM BUILT
 FOODSERVICE
 EQUIPMENT



AMERASPEC SERIES